

INCH-POUND

MS25082P
1 MARCH 1996
SUPERSEDING
MS25082N
26 AUGUST 1992

MILITARY SPECIFICATION SHEET

NUT, PLAIN, HEXAGON
ELECTRICAL - THIN

THIS SPECIFICATION IS APPROVED FOR USE BY ALL DEPARTMENTS
AND AGENCIES OF THE DEPARTMENT OF DEFENSE

THE REQUIREMENTS FOR ACQUIRING THE PRODUCT DESCRIBED HEREIN SHALL CONSIST
OF THIS SPECIFICATION SHEET AND THE ISSUE OF THE FOLLOWING DOCUMENT
LISTED IN THAT ISSUE OF THE DEPARTMENT OF DEFENSE INDEX OF SPECIFICATIONS
AND STANDARDS (DODISS) SPECIFIED IN THE SOLICITATION

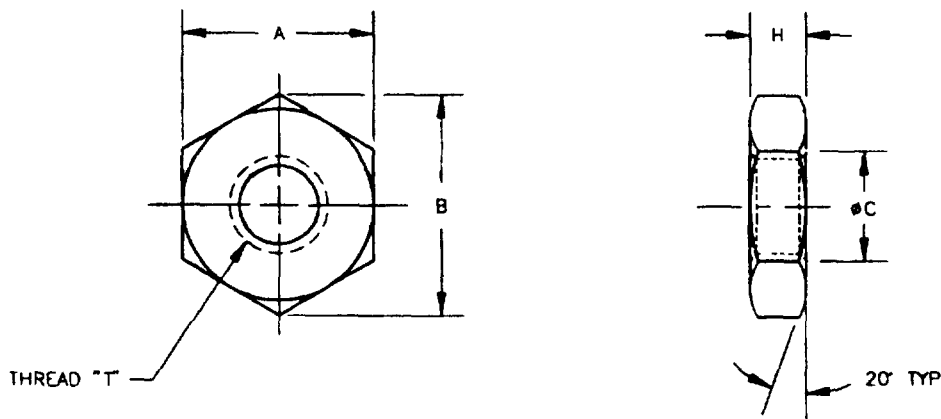

FIGURE 1 DIMENSIONS AND CONFIGURATIONS.

(P) ENTIRE DOCUMENT REVISED

MS25082P

TABLE I. DIMENSIONS

DASH NUMBER				T THREAD	A		B		#C MAX	H ± .005
STEEL CAD PLATED	CRES	BRASS OXIDE COATED	BRASS SILVER PLATED		MAX	MIN	MAX	MIN		
1	C1	B1	S1	1380-32 UNC-2B	312	302	361	344	168	.078
2	C2	B2	S2	1640-32 UNC-2B	344	332	397	378	194	.078
3	C3	B3	S3	1900-32 UNF-2B	375	362	433	413	220	.078
12	C12	B12	S12	1900-32 UNF-2B	250	241	289	275	220	.078
4	C4	B4	S4	2500-28 UNF-2B	438	428	505	488	280	.089
13	C13	B13	S13	2500-32 UNEF-2B	312	302	361	344	.280	.078
26	C26	B26	S26	2500-36 UNS-2B	312	302	361	344	280	.063
14	C14	B14	S14	2500-40 UNS-2B	312	302	361	344	280	.063
5	C5	B5	S5	3125-24 UNF-2B	.562	545	650	621	.342	.104
23	C23	B23	S23	3125-32 UNEF-2B	444	423	505	482	342	.093
24	C24	B24	S24	3125-32 UNEF-2B	562	545	650	621	342	.078
6	C6	B6	S6	3750-24 UNF-2B	625	607	722	692	405	.104
7	C7	B7	S7	3750-32 UNEF-2B	562	545	650	621	405	.078
20	C20	B20	S20	3750-32 UNEF-2B	562	545	650	621	405	.093
18	C18	B18	S18	4375-32 UN-2B	500	489	577	557	472	.093
25	C25	B25	S25	4375-32 UN-2B	562	545	650	621	472	.093
8	C8	B8	S8	4688-32 UNS-2B	562	545	650	621	.510	.078
21	C21	B21	S21	4688-32 UNS-2B	562	.545	650	621	.510	.093
19	C19	B19	S19	5000-28 UNEF-2B	625	609	722	692	540	.109
15	C15	B15	S15	5000-32 UN-2B	.562	545	650	621	540	.078
22	C22	B22	S22	5000-32 UN-2B	562	545	650	621	540	.093
10	C10	B10	S10	6250-18 UNF-2B	.812	.788	938	.895	.675	.139
11	C11	B11	S11	6250-24 UNEF-2B	750	736	866	840	.675	.104
16	C16	B16	S16	6875-27 UNS-2B	812	788	938	895	730	.093
17	C17	B17	S17	1 000-27 UNS-2B	1 125	1 088	1 299	1 240	1 060	.093

FIGURE 1 DIMENSIONS AND CONFIGURATIONS. - CONTINUED

NOTES.

- 1 A AND B DIMENSIONAL RANGES HAVE BEEN REVISED ON SOME OF THE DASH NUMBERS TO CONFORM WITH ANSI B18 2 2 AND ANSI B18 6 3
- 2 FOR BRASS NUTS MANUFACTURED FROM MILLED BAR ONLY, THE TABULATED MAXIMUM WIDTH ACROSS FLATS DIMENSIONS MAY BE EXCEEDED TO CONFORM WITH THE COMMERCIAL TOLERANCES OF DRAWN OR ROLLED BAR STOCK MATERIAL. THE NOMINAL BAR SIZE USED SHALL BE THE CLOSEST COMMERCIALY AVAILABLE SIZE TO THE SPECIFIED BASIC WIDTH ACROSS THE FLATS, AND ACROSS CORNERS OF THE NUT
- 3 NUTS MANUFACTURED PRIOR TO REVISION "P" ARE ACCEPTABLE UP TO TWO YEARS FROM DATE OF REVISION "P"
- 4 PART NUMBERS MS25082-9 AND MS25082-B9 WERE CANCELLED AFTER 8 OCTOBER 1968 AND REPLACED BY MS25082-11 AND MS25082-B11 RESPECTIVELY
- 5 IN THE EVENT OF A CONFLICT BETWEEN THE TEXT OF THIS DOCUMENT AND THE REFERENCES CITED HEREIN THE TEXT OF THIS DOCUMENT SHALL TAKE PRECEDENCE
- 6 UNLESS OTHERWISE SPECIFIED REFERENCED DOCUMENTS ARE THOSE IN EFFECT AT THE TIME OF SOLICITATION

MS25082P

REQUIREMENTS.1 MATERIALS.

STEEL COMPOSITIONS IN ACCORDANCE WITH FED-STD-66, 55 KSI MINIMUM TENSILE STRENGTH (SULFUR OR PHOSPHORUS SHALL NOT EXCEED .050 BY WEIGHT FOR NUTS HEAT TREATED TO ROCKWELL HARDNESS C36 OR GREATER)

BRASS COMPOSITION 360 WITH H02 TEMPER (UNS C36000) IN ACCORDANCE WITH ASTM B16

CRES (STAINLESS STEEL) COMPOSITION 303 (UNS S30300) IN ACCORDANCE WITH ASTM A581 OR A582

2 FINISH/PLATING.

STEEL NUTS SHALL BE CADMIUM PLATED PER QQ-P-416, TYPE II, CLASS 2

BRASS NUTS SHALL BE SILVER PLATED PER QQ-S-365 OR BLACK OXIDE FINISH PER MIL-F-495

CRES NUTS SHALL BE PASSMATED PER QQ-P-35

3 THREADS SHALL BE IN ACCORDANCE WITH FED-STD-H2B/2 THREAD ACCEPTABILITY SHALL BE IN ACCORDANCE WITH FED-STD-H2B/20, SYSTEM 214 BREAK ALL SHARP EDGES AND REMOVE ALL BURRS THE CHAMFER OR COUNTERSINK AT BOTH EDGES OF TAPPED HOLE SHALL NOT BE GREATER THAN .005 INCH5 DIMENSIONS ARE IN INCHES UNLESS OTHERWISE SPECIFIED, TOLERANCE FOR ANGLES SHALL BE $\pm 5'$ 6 BEARING SURFACE THE DIAMETER OF THE CIRCLE OF THE BEARING SURFACE SHALL BE THE MAXIMUM ACROSS FLATS DIMENSION WITHIN A TOLERANCE OF MINUS THREE PERCENT THE BEARING SURFACE SHALL BE PERPENDICULAR TO THE THREAD AXIS WITHIN $2'$ FOR NUTS $.625$ INCH AND SMALLER AND $1'$ FOR NUTS LARGER THAN $.625$ INCH7 PART NUMBER THE PART NUMBER SHALL CONSIST OF THE BASIC MS NUMBER FOLLOWED BY A DASH NUMBER FROM TABLE 1

EXAMPLE MS25082 - 1

MS25082-1 INDICATES STEEL, CADMIUM PLATED, $1/8$ INCH NOMINAL THREADED, CLASS 2B, PLAIN HEXAGON NUT

MILITARY INTERESTSCUSTODIANS

ARMY - AR
NAVY - AS
AIR FORCE - 99

PREPARING ACTIVITY

DLA-IS

(PROJECT 5310-2037)

REVIEWER.

ARMY - AV, ER
NAVY - EC, MC
AIR FORCE - 82