

FED. SUP CLASS
5305

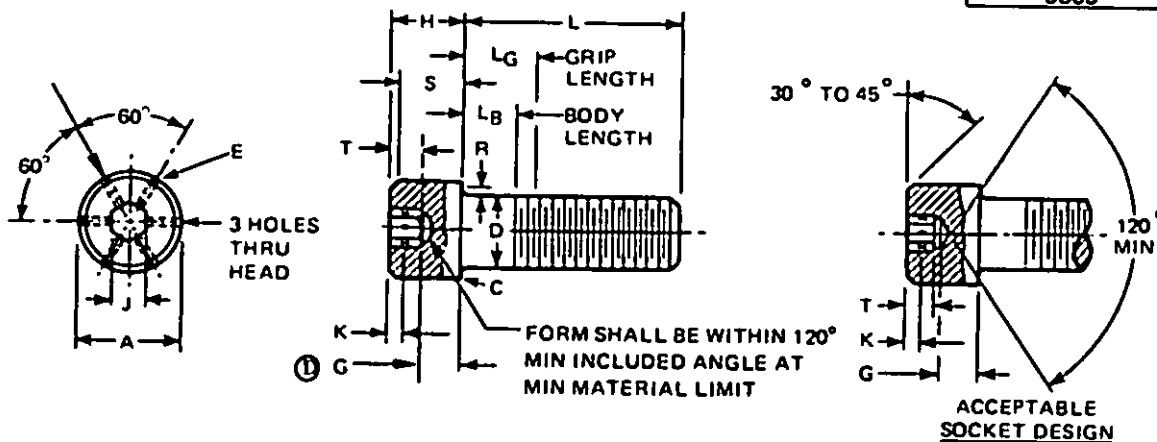

USER ACTIVITIES:
Army - AT, ME
Navy - AS, SH

REVIEWER ACTIVITIES:
Army - MI
Navy - MC
Air Force - II
DLA - IS

This military standard is approved for use by all Departments and Agencies of the Department of Defense. Selection for all new engineering and design applications and for repetitive use shall be made from this document.

Nominal size		#10 (.190)		1/4 (.250)		5/16 (.3125)		3/8 (.375)	
Threads per inch (UNF-3A)		32		28		24		24	
D	Body diameter	Max	0.1900	0.2500	0.3125	0.3750			
		Min	0.1840	0.2435	0.3053	0.3678			
A	Head diameter	Max	0.312	0.375	0.469	0.562			
		Min	0.303	0.365	0.457	0.550			
H	Head height	Max	0.190	0.250	0.312	0.375			
		Min	0.185	0.244	0.306	0.368			
S	Head side height	Min	0.171	0.225	0.281	0.337			
J	Socket width across flats	Max	0.1587	0.1900	0.2530	0.3160			
		Min	0.1562	0.1875	0.2500	0.3125			
T	Key engagement	Min	0.090	0.120	0.151	0.182			
G	Wall thickness	Min	0.065	0.095	0.119	0.143			
C	Chamfer or radius	Max	0.005	0.008	0.008	0.008			
R	Fillet extension	Max	0.014	0.014	0.017	0.020			
		Min	0.009	0.009	0.012	0.015			
K	Hole location	Max	0.065	0.085	0.104	0.123			
		Min	0.045	0.065	0.084	0.103			
E	Hole diameter	Max	0.050	0.050	0.050	0.067			
		Min	0.044	0.044	0.044	0.061			
	Recommended wire diameter	Max	0.040	0.040	0.040	0.057			
		Min	0.032	0.032	0.032	0.045			
	Alignment plug diameter		0.030	0.030	0.030	0.051			
**	Tensile strength, lbs	Min	1,600	2,920	4,640	7,020			

L Length	Tolerance	Dash no.	L _G Max	L _B Min	Dash no.	L _G Max	L _B Min	Dash no.	L _G Max	L _B Min	Dash no.	L _G Max	L _B Min
0.375		-1											
0.500		-2			-9								
0.625	+0.00	-3			-10								
0.750	-0.03	-4			-11						-19		
0.875		-5											
1.000		-6			-12								
1.250	+0.00	-7	0.38	0.17	-13			-16			-20		
1.500	-0.04	-8	0.38	0.17	-14	0.50	0.25	-17			-21		
								-18			-22		

For NOTES see SHEET 2.

Ⓛ denotes changes

P.A.	OS	INTERNATIONAL INTEREST	TITLE	MILITARY STANDARD
Other Cust	AR 99		SCREW, CAP, SOCKET HEAD, HEXAGON, DRILLED CORROSION-RESISTING STEEL (UNF-3A)	MS 24673
Procurement Specification	FF-S-86	SUPERSEDES:		SHEET 1 OF 2

APPROVED 7 April 1960 REVISED 27 January 1961 7 July 1975 15 March 1976 9 November 1984

NOTES:

1. **MATERIAL:** Austenitic corrosion-resisting steel in accordance with FF-S-86.
2. **PROTECTIVE COATING:** Passivate in accordance with QQ-P-35.
3. **MECHANICAL PROPERTIES:** Screws shall meet the mechanical property requirements of FF-S-86 as well as the magnetic permeability requirements specified in Note 4.
4. **MAGNETIC PERMEABILITY:** Screws shall have a magnetic permeability of 2.0 MAX (Air = 1.0) for a field strength of H = 200 oersteds, using a magnetic indicator conforming to MIL-I-17214, or equivalent.
5. **THREADS:** Threads shall be in accordance with MIL-S-7742.
6. **THREAD LENGTH:** Screws above heavy line shall have complete (full form) threads extending within two threads of the head as measured with a thread ring gage.
7. **HEAD:** Head may or may not be knurled at manufacturer's option. Type of knurling optional. Diameter of knurled head shall not exceed the maximum head diameter specified.
8. **DRILLED HOLE DATA:**
 - (a) Edges of the holes on the outside of the head shall be chamfered 45° by 0.010 to 0.020 deep.
 - (b) Drilled holes shall be within the flats of the hexagon socket and shall not break the corners of the hexagon socket.
- *9. **ALIGNMENT PLUG:** Plug shall pass completely through the head without deflection.
- **10. **TENSILE STRENGTH:** Based on 80,000 PSI minimum ultimate tensile strength. Load pounds calculated by the stress areas indicated in Fed-STD-H28.
11. **DIMENSIONS:** Dimensions are in inches, unless otherwise specified.
12. **PART NUMBER:** The MS part number consists of the MS number, plus the dash number.
Example: MS 24673-1 is the part number for a screw .190-32UNF-3A by 0.375 long of corrosion-resisting steel.
13. **OTHER NOTES:**
 - (a) Referenced documents shall be of the issue in effect on date of invitation for bids.
 - (b) For design feature purposes, this standard takes precedence over procurement documents referenced herein.

APPROVED 7 April 1960 REVISED ① For changes see sheet 1.

This military standard is approved for use by all Departments and Agencies of the Department of Defense. Selection for all new engineering and design applications and for repetitive use shall be made from this document.

P.A.	OS	INTERNATIONAL INTEREST	TITLE	MILITARY STANDARD
Other Cust	AR 99		SCREW, CAP, SOCKET HEAD, HEXAGON, DRILLED CORROSION- RESISTING STEEL (UNF-3A)	MS 24673
Procurement Specification	SUPERSEDES:		SHEET	2 OF 2
FF-S-86				