

FED. SUP CLASS  
5305

NOTICE: When Government drawings, specifications, or other data are used for any purpose other than in connection with a definitely related Government procurement operation, the United States Government thereby incurs no responsibility, nor any obligation whatsoever; and the fact that the Government may have furnished, furnished, or in any way supplied the said drawings, specifications, or other data is not to be regarded by implication or otherwise as in any manner licensing the holder or any other person or corporation, or conveying any rights or permission to manufacture, use, or sell any particular invention that may in any way be related thereto.

This military standard is approved by the Department of Defense and is mandatory on all activities. Selection for all new engineering and design applications and for repetitive use shall be made from this document.

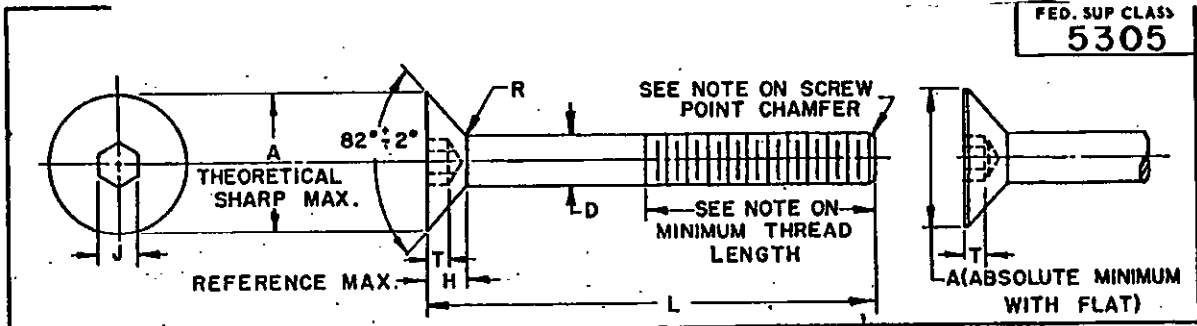

|                             |                             |                |                |                |                |                |  |    |  |    |    |
|-----------------------------|-----------------------------|----------------|----------------|----------------|----------------|----------------|--|----|--|----|----|
| NOMINAL SIZE                |                             | #10 (.190)     | 1/4            | 5/16           | 3/8            | 1/2            |  |    |  |    |    |
| THREADS PER INCH            |                             | 32UNF-3A       | 28UNF-3A       | 24UNF-3A       | 24UNF-3A       | 20UNF-3A       |  |    |  |    |    |
| D. BODY DIAMETER            | MAX<br>MIN                  | .190<br>.1867  | .250<br>.2464  | .3125<br>.3084 | .375<br>.3705  | .500<br>.4948  |  |    |  |    |    |
| A HEAD DIAMETER             | THEO. SHARP MAX<br>ABS. MIN | .411<br>.359   | .531<br>.480   | .656<br>.600   | .781<br>.720   | .937<br>.872   |  |    |  |    |    |
| H HEAD HEIGHT               | REFERENCE MAX               | .127           | .161           | .198           | .234           | .251           |  |    |  |    |    |
| J SOCKET WIDTH ACROSS FLATS | MAX<br>MIN                  | .1270<br>.1250 | .1582<br>.1562 | .1895<br>.1875 | .2207<br>.2187 | .3155<br>.3125 |  |    |  |    |    |
| T KEY ENGAGEMENT            | MIN                         | .087           | .111           | .135           | .159           | .172           |  |    |  |    |    |
| R RADIUS                    | MAX                         | .019           | .025           | .031           | .037           | .050           |  |    |  |    |    |
| MINIMUM BREAKING STRENGTH   | LBS                         | 1400           | 2550           | 4060           | 6150           | 11200          |  |    |  |    |    |
| L LENGTH                    | TOL.                        | DASH No. FIIN. | DASH No. FIIN. | DASH No. FIIN. | DASH No. FIIN. | DASH No. FIIN. |  |    |  |    |    |
| 3/8                         | +1/64<br>-1/64              | 1              |                | 9              |                | 17             |  | 25 |  |    |    |
| 1/2                         |                             | 2              |                | 10             |                | 18             |  | 26 |  |    |    |
| 5/8                         |                             | 3              |                | 11             |                | 19             |  | 27 |  |    | 32 |
| 3/4                         |                             | 4              |                | 12             |                | 20             |  | 28 |  |    | 33 |
| 1                           |                             | 5              |                | 13             |                | 21             |  | 29 |  |    | 34 |
| 1-1/4                       | +1/32<br>-1/64              | 6              |                | 14             |                | 22             |  | 30 |  |    | 35 |
| 1-1/2                       |                             | 7              |                | 15             |                | 23             |  |    |  | 36 |    |
| 1-3/4                       |                             |                |                |                |                |                |  |    |  | 37 |    |
| 2                           |                             |                |                |                |                |                |  |    |  |    |    |

**MATERIAL:** STEEL, CORROSION RESISTING, IN ACCORDANCE WITH FEDERAL STANDARD #66, CLASS 303 OR CLASS 304; ULTIMATE LOAD - 70,000 PSI MIN TENSILE STRENGTH; PROOF LOAD - 30,000 PSI MIN YIELD STRENGTH; ELONGATION - 35 PERCENT MIN.

**PROTECTIVE COATING:** PASSIVATED IN ACCORDANCE WITH THE PROCUREMENT SPECIFICATION.

**THREADS:** THE THREADS SHALL BE IN ACCORDANCE WITH SCREW-THREAD STANDARDS FOR FEDERAL SERVICES, HANDBOOK H-28.

**MINIMUM THREAD LENGTH:** THE MINIMUM USABLE THREAD LENGTH SHALL BE EQUAL TO 2D PLUS 1/2". THE THREAD LENGTH TOLERANCE SHALL BE EQUAL TO THE NOMINAL DIAMETER. SCREWS TOO SHORT FOR APPLICATION OF THE FORMULA SHALL BE THREADED AS CLOSE TO THE HEAD AS PRACTICABLE.

**POINT CHAMFER:** THE POINTS SHALL BE FLAT AND CHAMFERED. THE FLAT SHALL BE NORMAL TO THE AXIS OF THE SCREW. THE CHAMFER SHALL EXTEND SLIGHTLY BELOW THE ROOT OF THE THREAD AND THE EDGE BETWEEN THE FLAT AND THE CHAMFER MAY BE ROUNDED. THE INCLUDED ANGLE OF THE THREADED POINT SHALL BE APPROXIMATELY 90°. CHAMFERING OF SCREW SIZES UP TO AND INCLUDING #8 SHALL BE AT THE OPTION OF THE MANUFACTURER.

**DIMENSIONS:** ALL DIMENSIONS ARE IN INCHES UNLESS OTHERWISE SPECIFIED.

**PART NUMBER:** THE MS PART NUMBER CONSISTS OF THE MS NUMBER, PLUS THE DASH NUMBER. EXAMPLE: MS24672-1.

**NOTES:** (1) REFERENCED DOCUMENTS SHALL BE OF THE ISSUE IN EFFECT ON DATE OF INVITATIONS FOR BID.  
(2) THIS STANDARD TAKES PRECEDENCE OVER DOCUMENTS REFERENCED HEREIN.

Ⓐ CANCELLED AFTER 27 MAR. 61.  
NO SUPERSEDING STANDARD

|                                      |  |                              |
|--------------------------------------|--|------------------------------|
| P.A.<br>ORD<br>Other Cust<br>SHIPS   | TITLE<br>SCREW, CAP, SOCKET HEAD, FLAT COUNTERSUNK,<br>CORROSION RESISTING STEEL, UNF-3A | MILITARY STANDARD<br>MS24672 |
| PROCUREMENT SPECIFICATION<br>FF-S-86 | SUPERSEDES:  | SHEET 1 OF 1                 |

APPROVED GARR 60 REVISED Ⓐ 27 MAR. 61.