

INCH-POUND

MS17830E  
 22 SEPTEMBER 1998  
 Superseding  
 MS17830D  
 4 October 1968

## MILITARY SPECIFICATION SHEET

NUT, SELF-LOCKING, HEXAGON-REGULAR,  
 250 °F, AND 450 °F (NON-METALLIC INSERT),  
 300 SERIES CORROSION RESISTANT STEEL

This specification is approved for use by all Departments  
 and Agencies of the Department of Defense.

The requirements for acquiring the product described herein shall consist of this specification sheet and the issue of the following specification listed in that issue of the Department of Defense Index of Specifications and Standards (DoDISS) specified in the solicitation: MIL-N-25027.

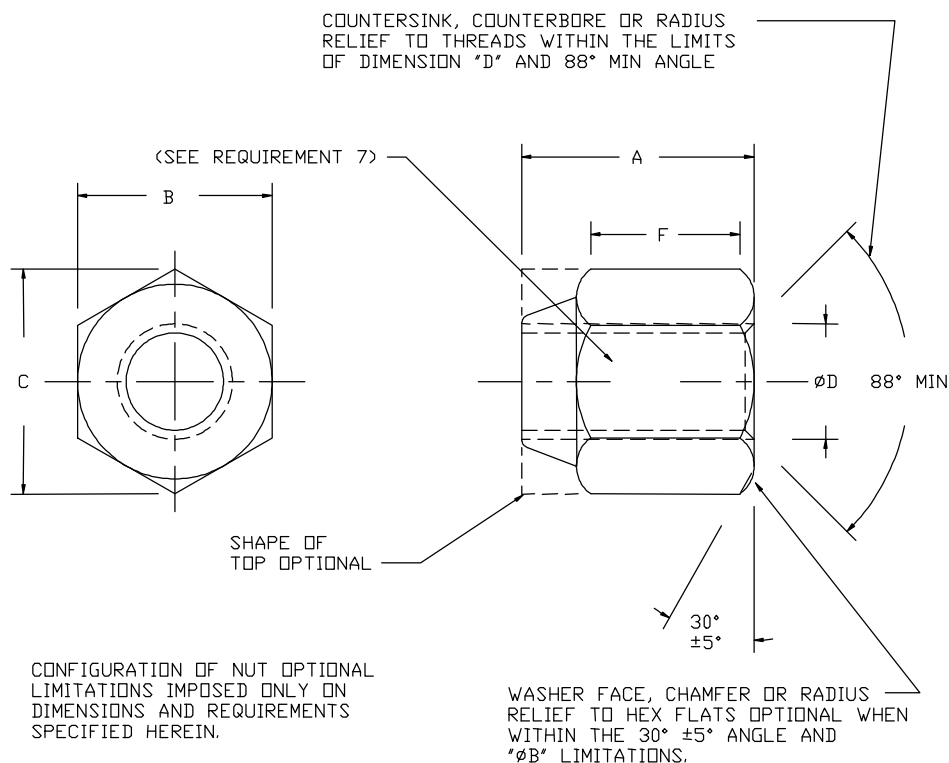

## MS17830E



TABLE I DASH NUMBERS, DIMENSIONS, AND SURFACE SQUARENESS

DASH NUMBER	NOMINAL THREAD SIZE	A		ØB		C	ØD	F	(a) BEARING SURFACE SQUARENESS
		MAX	MIN	MAX	MIN	MIN	±.020	MIN	
01C	.0730-64 UNJC-3B	.157	.133	.251	.243	.268	.095	.044	.005
02C	.0860-56 UNJC-3B	.157	.133	.251	.243	.268	.101	.044	.005
03C	.0990-48 UNJC-3B	.157	.133	.251	.243	.268	.122	.044	.005
04C	.1120-40 UNJC-3B	.157	.133	.251	.243	.268	.136	.044	.005
05C	.1250-40 UNJC-3B	.157	.133	.251	.243	.268	.149	.044	.005
06C	.1380-32 UNJC-3B	.188	.160	.313	.305	.339	.161	.061	.006
08C	.1640-32 UNJC-3B	.281	.219	.345	.336	.374	.188	.091	.006
010C (b)	.1900-24 UNJC-3B	.281	.208	.376	.367	.410	.210	.085	.006
010F (b)	.1900-32 UNJF-3B	.281	.208	.376	.367	.410	.210	.085	.006
012C	.2160-24 UNJC-3B	.328	.298	.439	.430	.482	.243	.099	.007
012F	.2160-28 UNJF-3B	.328	.298	.439	.430	.482	.243	.099	.007
4C	.2500-20 UNJC-3B	.360	.240	.439	.428	.482	.273	.116	.007
4F	.2500-28 UNJF-3B	.360	.240	.439	.428	.482	.273	.116	.007
5C	.3125-18 UNJC-3B	.360	.271	.502	.492	.552	.336	.123	.007
5F	.3125-24 UNJF-3B	.360	.271	.502	.492	.552	.336	.123	.007
6C	.3750-16 UNJC-3B	.469	.318	.564	.553	.622	.398	.153	.008
6F	.3750-24 UNJF-3B	.469	.318	.564	.553	.622	.398	.153	.008
7C	.4375-14 UNJC-3B	.469	.435	.690	.679	.766	.467	.178	.008
7F	.4375-20 UNJF-3B	.469	.435	.690	.679	.766	.467	.178	.008
8C	.5000-13 UNJC-3B	.610	.575	.752	.741	.837	.531	.221	.009
8F	.5000-20 UNJF-3B	.610	.575	.752	.741	.837	.531	.221	.009
9C	.5625-12 UNJC-3B	.704	.623	.877	.865	.978	.594	.243	.010
9F	.5625-18 UNJF-3B	.704	.623	.877	.865	.978	.594	.243	.010
10C	.6250-11 UNJC-3B	.766	.732	.940	.928	1.051	.656	.274	.010
10F	.6250-18 UNJF-3B	.766	.732	.940	.928	1.051	.656	.274	.010
12C	.7500-10 UNJC-3B	.891	.855	1.064	1.052	1.191	.782	.316	.010
12F	.7500-16 UNJF-3B	.891	.855	1.064	1.052	1.191	.782	.316	.010
14C	.8750-9 UNJC-3B	1.016	.965	1.252	1.239	1.403	.918	.570	.011
14F	.8750-14 UNJF-3B	1.016	.965	1.252	1.239	1.403	.918	.570	.011
16C	1.0000-8 UNJC-3B	1.141	1.010	1.440	1.427	1.615	1.044	.635	.012
16F	1.0000-12 UNJF-3B	1.141	1.010	1.440	1.427	1.615	1.044	.635	.012
18C	1.1250-7 UNJC-3B	1.266	1.130	1.627	1.614	1.826	1.171	.710	.013
18F	1.1250-12 UNJF-3B	1.266	1.130	1.627	1.614	1.826	1.171	.710	.013
18U	1.1250-8 UNJ-3B	1.266	1.130	1.627	1.614	1.826	1.171	.710	.013
20C	1.2500-7 UNJC-3B	1.454	1.300	1.814	1.801	2.038	1.295	.795	.014
20F	1.2500-12 UNJF-3B	1.454	1.300	1.814	1.801	2.038	1.295	.795	.014
20U	1.2500-8 UNJ-3B	1.454	1.300	1.814	1.801	2.038	1.295	.795	.014
22C	1.3750-6 UNJC-3B	1.609	1.547	2.008	1.973	2.232	1.447	.890	.015
22F	1.3750-12 UNJF-3B	1.609	1.547	2.008	1.973	2.232	1.447	.890	.015
22U	1.3750-8 UNJ-3B	1.609	1.547	2.008	1.973	2.232	1.447	.890	.015
24C	1.5000-6 UNJC-3B	1.640	1.578	2.197	2.159	2.444	1.568	.980	.016
24F	1.5000-12 UNJF-3B	1.640	1.578	2.197	2.159	2.444	1.568	.980	.016
24U	1.5000-8 UNJ-3B	1.640	1.578	2.197	2.159	2.444	1.568	.980	.016
28C	1.7500-5 UNJC-3B	2.376	2.250	2.762	2.715	3.075	1.818	1.250	.018
28U	1.7500-8 UNJ-3B	2.376	2.250	2.762	2.715	3.075	1.818	1.250	.018
32C	2.0000-4.5 UNJC-3B	2.469	2.343	3.137	3.086	3.497	2.065	1.350	.020
32U	2.0000-8 UNJ-3B	2.469	2.343	3.137	3.086	3.497	2.065	1.350	.020
36C	2.2500-4.5 UNJC-3B	2.876	2.750	3.514	3.457	3.918	2.328	1.600	.020
36U	2.2500-8 UNJ-3B	2.876	2.750	3.514	3.457	3.918	2.328	1.600	.020
40C	2.5000-4 UNJC-3B	3.204	3.078	4.015	3.875	4.393	2.578	1.800	.020
40U	2.5000-8 UNJ-3B	3.204	3.078	4.015	3.875	4.393	2.578	1.800	.020

(a) BEARING SURFACE SQUARENESS MEASURED IN ACCORDANCE WITH MIL-N-25027.

(b) SEE NOTE 10 FOR SUPERSESSION INFORMATION

## MS17830E

TABLE II DASH NUMBERS, AXIAL STRENGTH, AND VARIOUS TORQUE VALUES

DASH NUMBER	AXIAL STRENGTH LB. MIN <u>1/</u>	MINIMUM ULTIMATE WRENCH TORQUE IN - LB <u>2/</u>	WEIGHT LB/100 REF.	MAXIMUM LOCKING TORQUE INSTALLATION OR REMOVAL (IN - LB) <u>2/</u>	MINIMUM BREAKAWAY TORQUE (IN - LB) <u>2/</u>
01C	330	3	.14	2.5	.2
02C	460	4	.14	2.5	.2
03C	610	4	.14	3	.3
04C	760	8	.14	5	.5
05C	1000	10	.14	7	.7
06C	1140	15	.26	10	1.0
08C	1750	23	.42	15	1.5
010C	2190	40	.50	18	2.0
010F	2500	46	.50	18	2.0
012C	3020	55	.92	22	2.5
012F	3220	60	.92	22	2.5
4C	3980	86	.9	30	4.5
4F	4550	115	.9	30	3.5
5C	6550	185	1.2	60	7.5
5F	7250	260	1.2	60	6.5
6C	9690	315	1.8	80	12.0
6F	10975	450	1.8	80	9.5
7C	13300	550	2.3	100	16.5
7F	14850	965	2.3	100	14.0
8C	17750	1000	4.3	150	24
8F	20000	1265	4.3	150	18
9C	22750	1265	7.1	200	30
9F	25375	1840	7.1	200	24
10C	28250	1725	8.3	300	40
10F	32000	2760	8.3	300	32
12C	41750	2875	12	400	60
12F	46625	5750	12	400	50
14C	577750	5300	19	600	82
14F	63625	8050	19	600	70
16C	75750	8750	27	800	110
16F	82875	10990	27	800	90
18C	95375	13100	41	900	137
18F	107000	14850	41	900	117
18U	98750	13125	41	900	137
20C	121100	17600	58	1000	165
20F	134100	22500	58	1000	143
20U	125000	17650	58	1000	165
22C	144400	20000	77	1200	200
22F	164400	22500	77	1200	180
22U	153750	20175	77	1200	200
24C	175650	20000	100	1400	230
24F	197650	22500	100	1400	210
24U	186250	20175	100	1400	230
28C	237500	20000	240	1800	300
28U	260000	20000	240	1800	300
32C	312500	20000	310	2200	360
32U	346250	20000	310	2200	360
36C	406200	20000	450	2600	430
36U	445000	20000	450	2600	430
40C	500000	20000	682	3000	500
40U	555000	20000	682	3200	550

1/ AXIAL STRENGTH BASED ON 125,000 PSI STRESS2/ SEE MIL-N-25027

## MS17830E

## REQUIREMENTS:

1. MATERIAL:

LOCKNUT: CORROSION RESISTANT STEEL, ALLOYS UNS S30300, S30323, S30400, OR S30430, MATERIAL CONDITION COLD WORKED (CW) IN ACCORDANCE WITH ASTM A493, ASTM A581, ASTM A582, AMS 5640 OR QQ-S-763.

CORROSION RESISTANT STEEL, ALLOY UNS S31600, MATERIAL CONDITION COLD WORKED (CW) IN ACCORDANCE WITH ASTM A 479, ASTM A493, OR AMS 5648.

NON METALLIC LOCKING COLLAR (INSERT) SHALL BE IN ACCORDANCE WITH ASTM D4066, GROUP 1, CLASS 1 OR 2 FOR 250°F, OR MIL-R-46198, TYPE 1 FOR 450°F, AS SPECIFIED IN PART NUMBER.

2. LOCKING DEVICE: THE LOCKING DEVICE SHALL BE A COLLAR INSERT CAPABLE OF COMPLETE CIRCUMFERENTIAL THREAD ENGAGEMENT FOR AT LEAST ONE FULL THREAD.

3. THREADS: THREADS SHALL BE RIGHT HAND UNJ, UNJC OR UNJF CLASS 3B IN ACCORDANCE WITH ASME B1.15. THREAD ACCEPTABILITY SHALL BE IN ACCORDANCE WITH ASME B1.3, SYSTEM 21.

4. BOLTS OR STUDS: BOLTS OR STUDS FOR MAXIMUM LOCKING TORQUE AND MINIMUM BREAKAWAY TORQUE TEST SHALL BE CORROSION RESISTANT STEEL.

5. SURFACE TREATMENT: PASSIVATE IN ACCORDANCE WITH ASTM A967.

6. SURFACE TEXTURE: SHALL BE Ra 125 MICROINCHES MAXIMUM IN ACCORDANCE WITH ASME B46.1.

7. MARKING: LOCKNUTS .2500 AND LARGER SHALL BE MARKED ON THE WRENCH FLAT AS INDICATED BELOW. LOCKNUTS .2160 AND SMALLER SHALL BE MARKED ON PACKAGE. LOCKNUTS OF NOMINAL THREAD SIZE .2500 AND LARGER SHALL HAVE MATERIAL MARKING AS FOLLOWS:

<u>UNS NUMBER</u>	<u>MARKING 250°F</u>	<u>MARKING 450°F</u>
S30300	303	303V
S30323	303Se	303SeV
S30400	304	304V
S30430	30430	30430V
S31600	316	316V

8. PART NUMBER: THE PART NUMBER SHALL CONSIST OF THE BASIC DOCUMENT NUMBER FOLLOWED BY A DASH NUMBER FROM TABLE I. ADD CODE "X" IN LIEU OF DASH TO INDICATE 450°F LOCKING FEATURE. ADD CODE "316" SUFFIX TO PART NUMBER TO INDICATE 316 STAINLESS STEEL. SEE EXAMPLES BELOW:

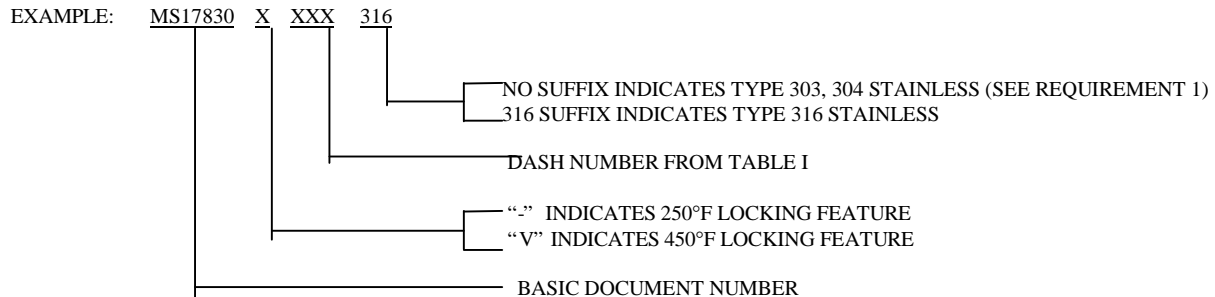

MS17830-4C = .250 NOMINAL THREAD SIZE, COARSE 3B THREAD STAINLESS STEEL, 250°F RATED LOCKING FEATURE.

MS17830V4C = .250 NOMINAL THREAD SIZE, COARSE 3B THREAD STAINLESS STEEL, 450°F RATED LOCKING FEATURE.

MS17830-4C316 = .250 NOMINAL THREAD SIZE, COARSE 3B THREAD STAINLESS STEEL TYPE 316, 250°F RATED LOCKING FEATURE.

MS17830V4C316 = .250 NOMINAL THREAD SIZE, COARSE 3B THREAD STAINLESS STEEL TYPE 316, 450°F RATED LOCKING FEATURE

MS17830E

NOTES:

1. DIMENSION IN INCHES, UNLESS OTHERWISE SPECIFIED, TOLERANCE: DECIMAL  $\pm$  .016.
2. INTERPRET DRAWING IN ACCORDANCE WITH ASME Y14.5M.
3. BREAK ALL SHARP EDGES .003 TO .005 AND REMOVE BURRS AND SLIVERS.
4. NO QPL REQUIRED FOR MS17830.
5. SUGGESTED REFERENCE TO IDENTIFY AISI ALLOY NUMBERS REFERENCED IN REQUIREMENT 7 IS SAE HS-1086/ASTM DS-56 (METALS AND ALLOYS IN THE UNIFIED NUMBERING SYSTEM).
6. IN THE EVENT OF A CONFLICT BETWEEN THE TEXT OF THIS DOCUMENT AND THE REFERENCES CITED HEREIN, THE TEXT OF THIS DOCUMENT SHALL TAKE PRECEDENCE.
7. UNLESS OTHERWISE SPECIFIED, ISSUES OF REFERENCED DOCUMENTS ARE THOSE IN EFFECT AT THE TIME OF SOLICITATION.
8. LOCKNUTS MANUFACTURED PRIOR TO DATE OF REVISION "D" ARE ACCEPTABLE FOR USE UNTIL EXHAUSTED..
9. CORROSION RESISTANT STEEL TYPE UNS S31600, WHEN OFFERED AS A SUBSTITUTE FOR TYPES UNS S30300, S30323, S30400, S30430 IS ACCEPTABLE IN ALL APPLICATIONS.
10. PART NUMBER MS17830-3C OF REVISION "C" IS REPLACED BY PART NUMBER MS17830-010C REVISION "D". PART NUMBER MS17830-3F OF REVISION "C" IS REPLACED BY PART NUMBER MS17830-010F REVISION "D".
11. MS17830 SUPERSEDES MIL-N-24129/3 (SHIPS), MS17830 (SHIPS).

F.

MILITARY INTERESTS:

CUSTODIANS:

ARMY – AV  
NAVY – AS  
AIR FORCE – 99

PREPARING ACTIVITY:  
DLA - IS

(Project 5310-2361)

REVIEW:

ARMY – CR4, MI  
NAVY – SH  
AIR FORCE – 11, 82