

INCH-POUND

NOTE: This draft, dated 25 November 1996 prepared by DLA-IS, has not been approved and is subject to modification. DO NOT USE FOR ACQUISITION PURPOSES. (Project 5310-2291)

MS14182B  
PROPOSED  
 Superseding  
 MS14182A  
 30 January 1989

## MILITARY SPECIFICATION SHEET

NUT, SELF-LOCKING, EXTENDED WASHER, ROUND,  
 NICKEL ALLOY 718, 220 KSI Ft<sub>u</sub>, 450°F AND 800°F, SPLINE DRIVE

This specification is approved for use by all Departments and Agencies of the Department of Defense.

The requirements for acquiring the product described herein shall consist of this specification sheet and the issue of the following specification listed in that issue of the Department of Defense Index of Specifications and Standards (DoDISS) specified in the solicitation: MIL-N-85730

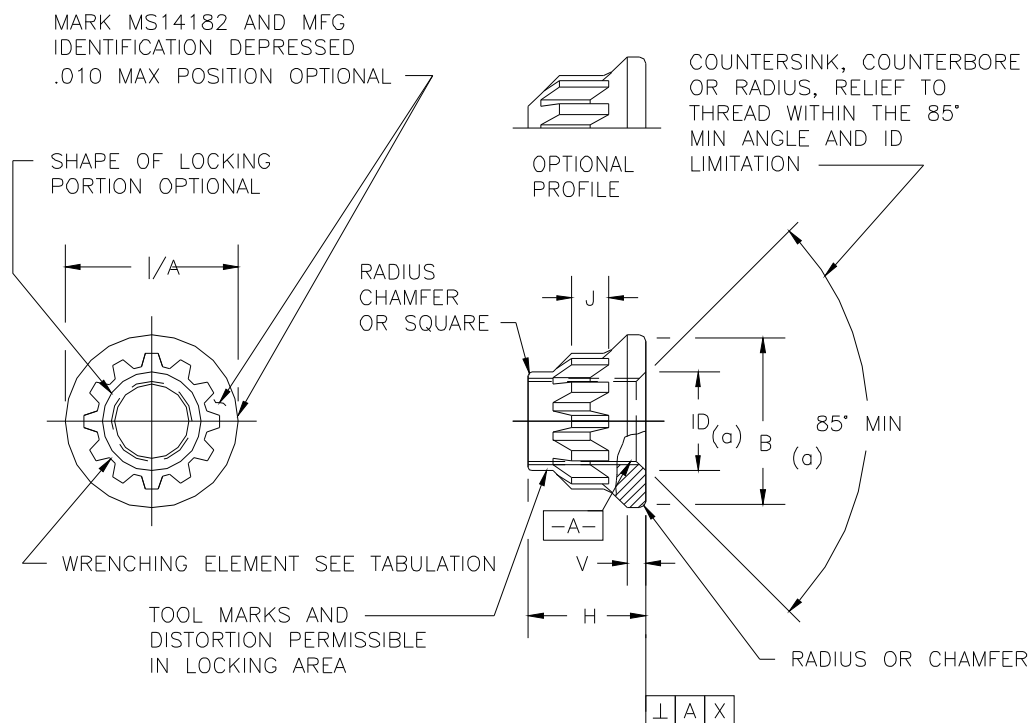

(B) Entire document revised

## MS14182B

Table I. Dash Numbers and Dimensions.

Dash Number	Nominal Size	Thread	MS33787 Element Number	A Max.	B (a) Min.	ID (a)		H Max.	V Min.	J Min.	X	Ultimate Axial Strength Lb.Min.(b)	Approx. Weight Lb/100
						Max.	Min.						
03	No.10	.1900-32UNJF-3B	8	.362	.322	.220	.190	.220	.023	.089	.003	4,970	.26
04	.250	.2500-28UNJF-3B	10	.460	.420	.280	.250	.290	.033	.110	.003	8,870	.51
05	.312	.3125-24UNJF-3B	12	.563	.522	.342	.312	.360	.038	.147	.003	14,100	.88
06	.375	.3750-24UNJF-3B	14	.669	.629	.405	.375	.430	.045	.176	.003	20,900	1.40
07	.437	.4375-20UNJF-3B	18	.773	.733	.473	.438	.500	.053	.206	.003	28,300	2.40
08	.500	.5000-20UNJF-3B	20	.879	.839	.535	.500	.575	.060	.235	.003	37,800	3.50
09	.562	.5625-18UNJF-3B	22	.982	.942	.597	.562	.650	.068	.264	.004	47,900	4.80
10	.625	.6250-18UNJF-3B	24	1.088	1.048	.660	.625	.720	.075	.294	.004	59,900	6.30
12	.750	.7500-16UNJF-3B	30	1.296	1.256	.785	.750	.860	.090	.353	.004	86,900	8.00
14	.875	.8750-14UNJF-3B	34	1.505	1.465	.910	.875	1.000	.105	.411	.005	119,000	9.90
16	1.000	1.0000-12UNJF-3B	38	1.720	1.670	1.035	1.000	1.150	.120	.470	.006	155,000	12.00

(a) Minimum bearing area based on a bearing stress of 115 KSI.

(b) Axial strength determined from formula  $W_a = f_t u A$  where A is the cross sectional area, in square inches, based on the maximum pitch diameter of bolt thread,  $f_t$  is 220 KSI and  $W_a$  is the axial strength in pounds.

## Requirements:

- Material: nickel alloy 718 per AMS 5662, AMS 5663 (UNS NO7718); capable of meeting strength requirements specified
- Surface texture: bearing surface 125 in accordance with ANSI/ASME B46.1.
- Finish: Nickel strike; coat with dry film lubricant per Mil-I-46010 Yype I.  
Cadmium plate per QQ-P-416; Type I, class 2.  
Silver Plate per AMS 2410 (0.0003-0.0005 thickness-threads only)
- Threads: MIL-S-8879 before lubrication.
- Wrenching element: (spline drive) per MS33787; drivers per MIL-W-8982.
- Performance per MIL-N-85730 except for:
  - Test bolts for axial strength, stress durability, torque effectively, locking torque, stress corrosion, accelerated vibration shall be nickel alloy 718, 220 KSI minimum ultimate tensile strength, dry film lubricated.
  - For torque effectively, reusability of dry film lubricated nuts shall be limited to five (5) cycles
  - For wrenching torque, bolts shall be 260,000 psi minimum
  - Baking temperature for torque effectively, vibration, and stress Durability shall be 800°F except dry film lubricated nuts and cadmium plated nuts shall be 450 °F.
- Part number: Part number shall consist of the ms designation plus finish Code and dash number.  
Add "P" after ms number to designate cadmium plate.  
Add "S" after ms number to designate silver plate.  
Add "L" after MS number to designate nickel strike/dry film lubricant.

Example: MS14182 S 14

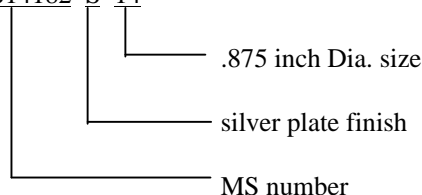

MS14182B

NOTES:

1. Dimensions in inches: Dimensions apply before lubrication.
2. Design and usage information: these nuts are designed to be used with MS14181 bolts and MS14183 washers. Cadmium plated and dry film lubricated nuts are not intended to be used in applications where temperatures exceed 450°F. Silver plated nuts are not intended to be used in applications where temperatures exceed 800 °F.

Military Interests:

Custodians:

Army - AV

Navy - AS

Air Force - 99

Preparing activity:

DLA - IS

(Project 5310-2291)

REVIEW:

Army - MI, AT,

Air Force - 82,